



DAMAS SIGMA



SKIOLD MAKES THE DIFFERENCE!

Function

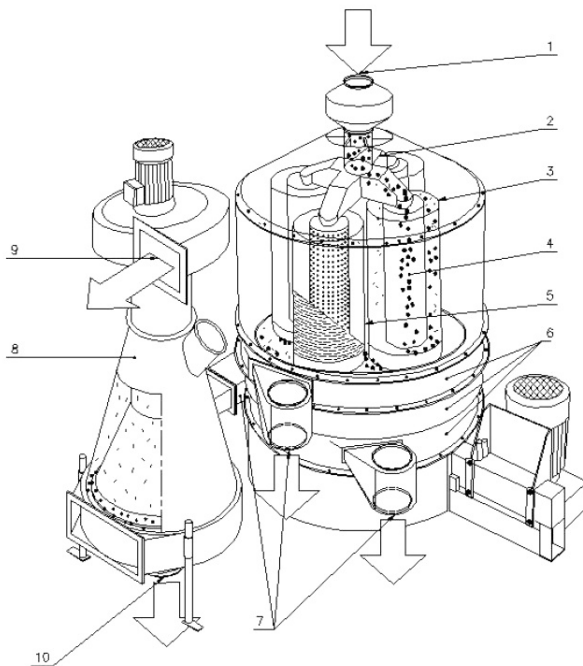

The raw material (1) is conveyed to the screen drums (3) via the distributor (2). The drums rotate in a planetary movement, i.e. around their own axis (4) while the drum axes rotate around the centre of the machine at the same time. The centrifugal force flings the grains towards the screen walls (5) and separation is achieved when the smaller grains pass through the screens. Large and coarse particles are removed on the inner screens. The grain is collected in channels (6) at the periphery of the machine and discharged from the outlets (7). The clean material leaves the machine through the outlet (10) of the aspirator (8). Light particles (9) are drawn by a fan to a cyclone or similar dust collector.

DAMAS SIGMA

Guiding capacities

Precleaning		752	753	754	1004	1004	756	756	1006	1006	1008	1008
		A	A	A	A	B	A	2A	A	2A	A	2B
Wheat, 18% H ₂ O	t/h	45	65	85	85	110	85	130	85	165	85	220
Barley, 18% H ₂ O	t/h	40	60	80	80	100	80	120	80	150	80	200
Maize, 35% H ₂ O	t/h	25	35	45	45	55	45	70	45	80	45	110
Maize, 45% H ₂ O	t/h	20	30	40	40	50	40	60	40	75	40	100
Rapeseed, 17% H ₂ O	t/h	30	50	60	60	80	60	100	60	120	60	160
Rice/sunflower, 18% H ₂ O	t/h	20	30	40	40	50	40	60	40	75	40	100

Intervention cleaning		752	753	754	1004	1004	756	756	1006	1006	1008	1008
		A	A	A	A	B	A	2A	A	2A	A	2B
Barley, 14% H ₂ O	t/h	20	30	40	50	50	60	60	75	75	80	100

Malting barley		752	753	754	1004	1004	756	756	1006	1006	1008	1008
		A	A	A	A	B	A	2A	A	2A	A	2B
20% separation	t/h	4	6	8	10	10	12	12	15	15	20	20
15% separation	t/h	6	9	12	15	15	18	18	22	22	30	30
10% separation	t/h	10	15	20	25	25	30	30	37	37	50	50

Industrial cleaning		752	753	754	1004	1004	756	756	1006	1006	1008	1008
		A	A	A	A	B	A	2A	A	2A	A	2B
Rapeseed, 9% H ₂ O	t/h	15	25	30	40	40	40	50	40	60	40	80
Rapeseed, 17% H ₂ O	t/h	10	15	20	25	25	30	30	30	40	30	50
Sunflower, 9% H ₂ O	t/h	20	30	40	45	45	45	55	45	70	45	90
Sunflower, 15% H ₂ O	t/h	16	24	30	35	35	35	40	35	50	35	70

Specifications

Motors		752	753	754	1004	1004	756	756	1006	1006	1008	1008
		A	A	A	A	B	A	2A	A	2A	A	2B
Main motor	kW	11	15	18.5	18.5	18.5	18.5	18.5	18.5	18.5	30	30
Air part	kW	0.37	0.37	0.37	0.37	0.37	0.37	2×0.37	0.37	2×0.37	0.37	2×0.37
Fan	kW	5.5	5.5	5.5	5.5	7.5	5.5	2×5.5	5.5	2×5.5	5.5	2×5.5
Rotary seal	kW	0.55	0.55	0.55	0.55	0.55	0.55	2×0.55	0.55	2×0.55	0.55	2×0.55

Air systems		752/754	1004	1004	756/1006	756/1006	1008	1008
		A	A	B	A	2A	A	2B
Open air system I-III	1000 m ³ /h	3 - 5	3 - 5	5 - 7	3 - 5	2×3 - 5	3 - 5	2×5 - 7
Recycling air system IV	1000 m ³ /h	1.2 - 1.5	1.2 - 1.5	1.5 - 2.0	1.2 - 1.5	2×1.2 - 1.5	1.2 - 1.5	2×1.5 - 2.0
Cyclone type		UC-110	UC-110	UC-140	UC-110	2×UC-110	UC-110	2×UC-140

• Type A uses aspirator type 80

• Type B uses aspirator type 120